

Simply45[®]

REVISIONS			
REV.	BY.	REVISIONS	DATE

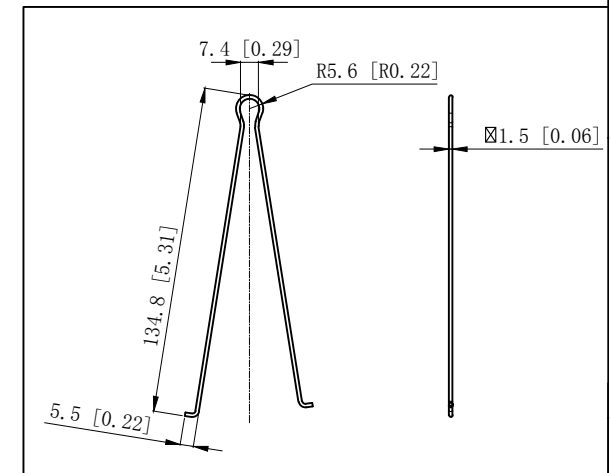
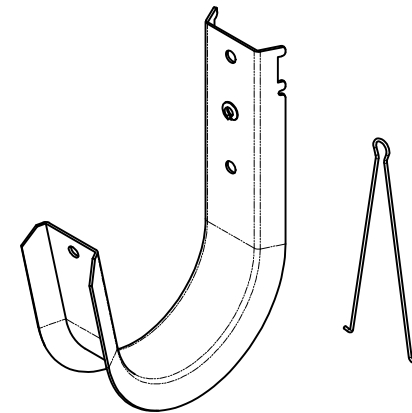
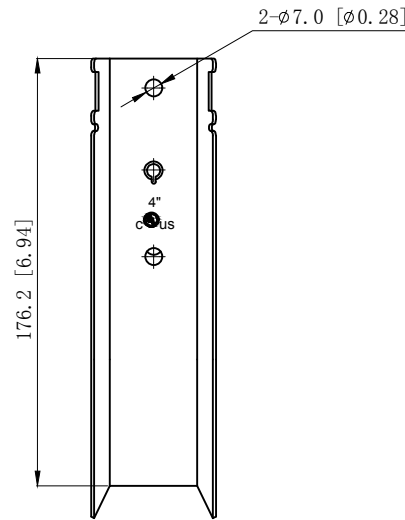
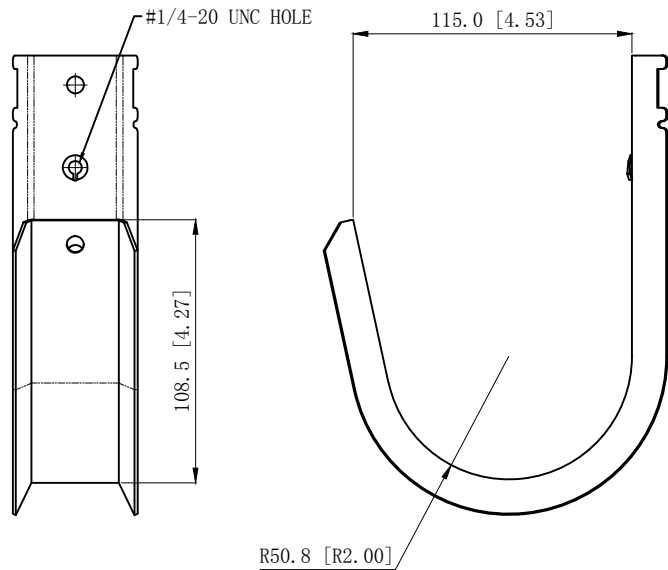

NOTES:

1. All dimensions in millimeters and [inches];
2. Material: C.R.S, thickness: 1.20 [0.047]
Finish: Yellow zinc plated, thickness: min 5um;
3. Free of sharp edge and burrs. max burr 0.127[0.005];

TOLERANCES UNLESS OTHERWISE SPECIFIED		NAME	DATE
INCHES	MILLIMETER	DRAMN	
ANGULAR:	ANGULAR:	CHECKED	
X.X: ±0.1	X: ±2.54	APPROVED (A)	
X.X X: ±0.05	X.X: ±1.27	APPROVED (Customer)	
X.X X X: ±0.008	X.X X: ±0.203		
MATERIAL		TITLE	
C.R.S			
FINISH		SIZE	DWG NO.
Yellow zinc plated		A4	S45-JH64-XX
		REV	A
		SCALE: 1:1	PRINT DATE
		REFERENCES	SHEET 1 OF 1

